

CARLO CRESCINI

Renders & Drafting Portfolio

RELIC (Feature Film)

Designer Stephen Jones-Evan

STUDIO SET DRAWINGS
Construction drawings

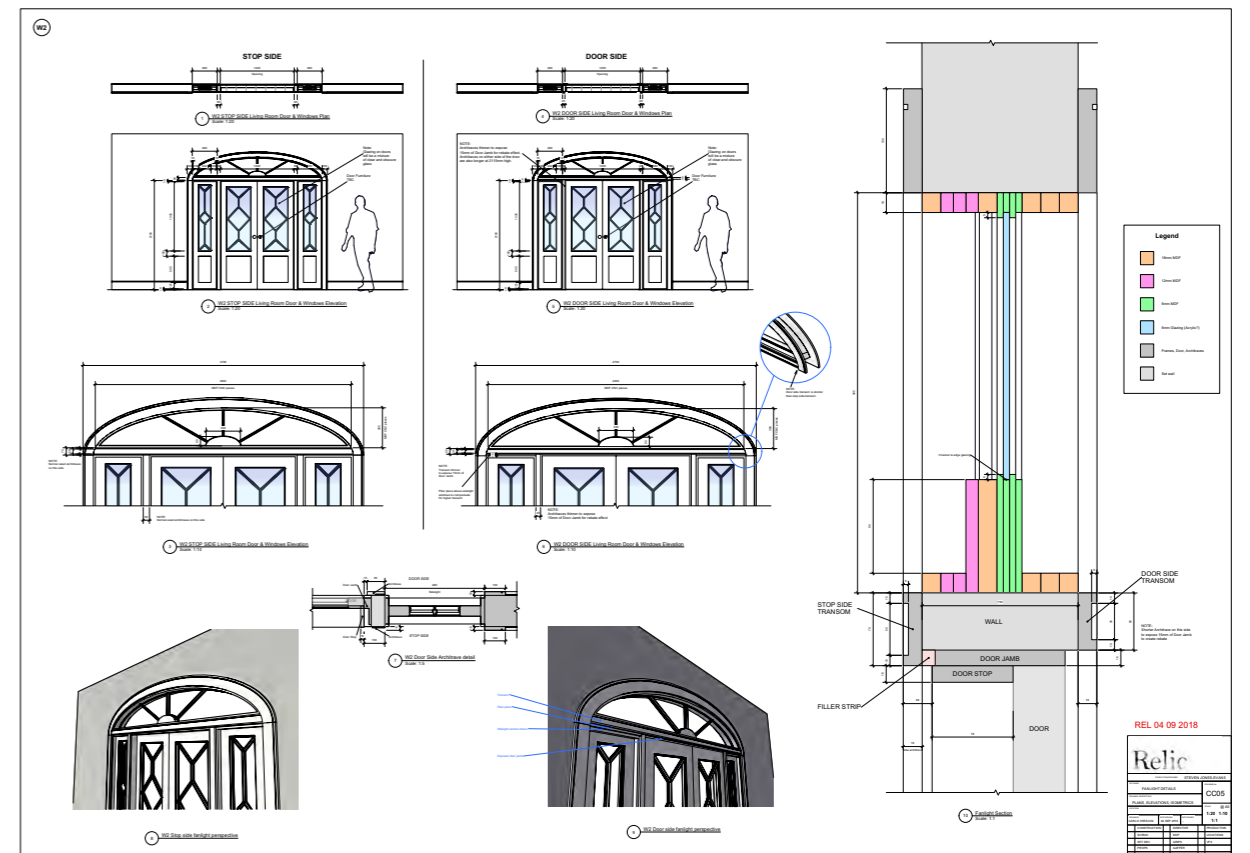
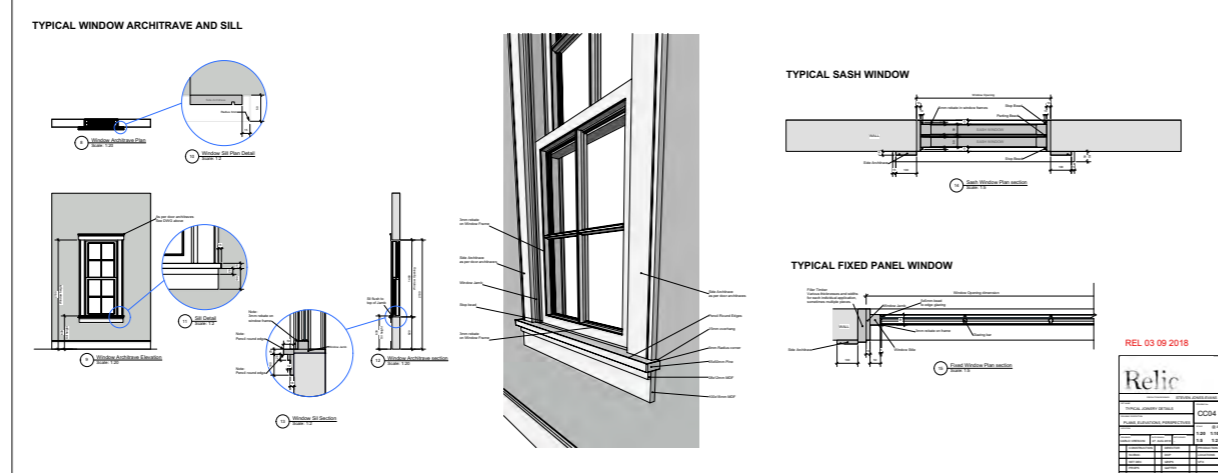
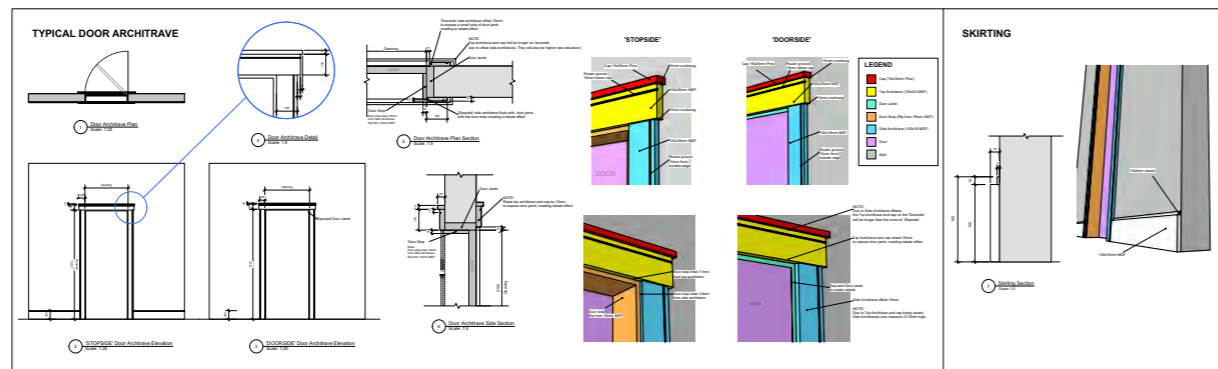
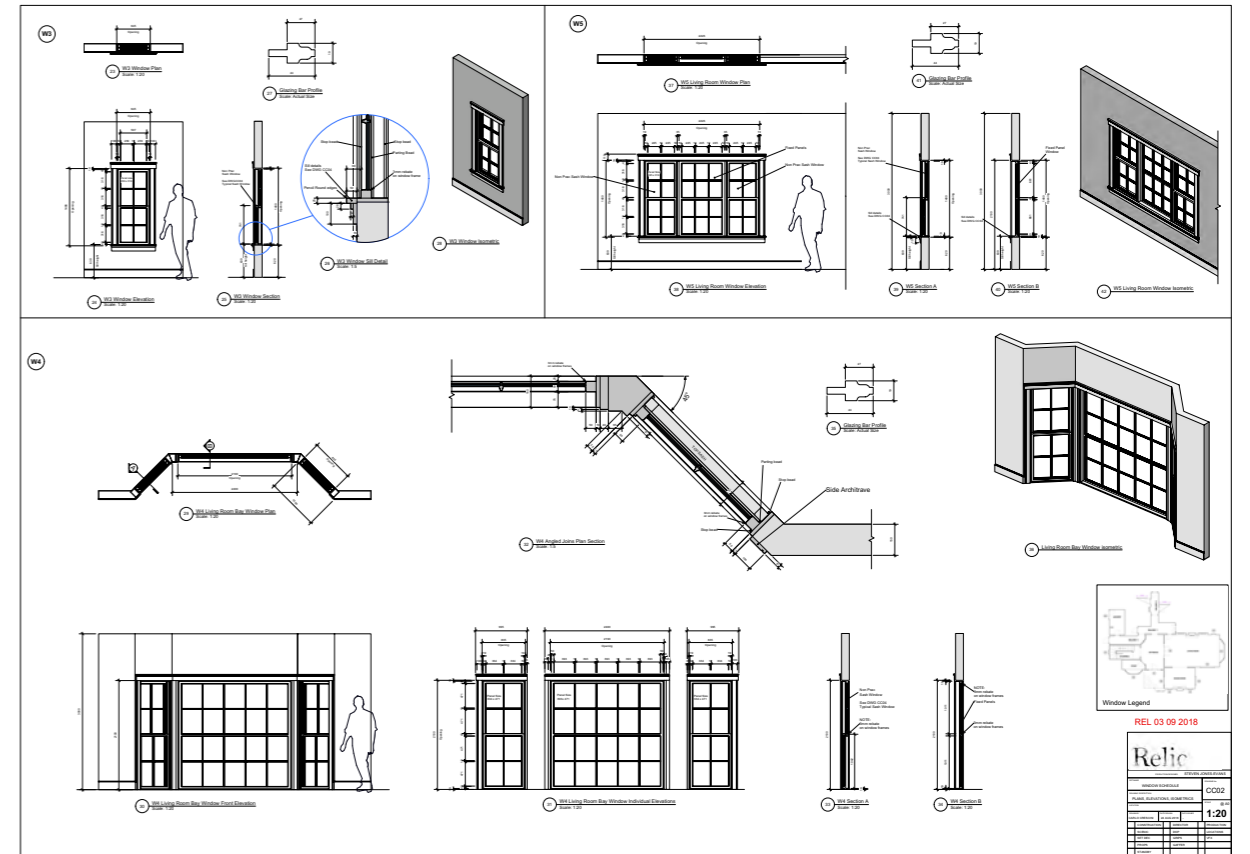
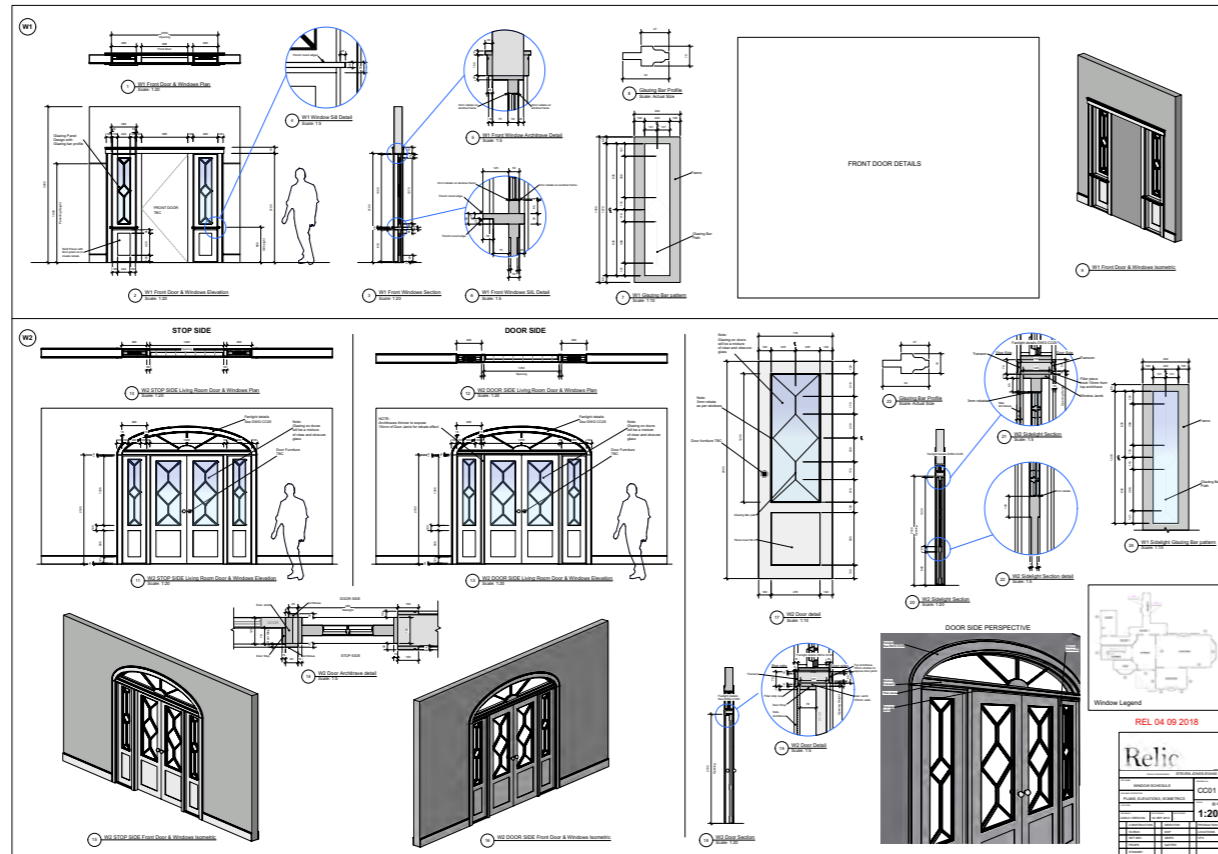

RELIC (Feature Film)

Designer Stephen Jones-Evan

STUDIO SET DRAWINGS Fireplace unit detail

1 Living room fireplace plan
Scale: 1:20

2 Living room fireplace elevation
Scale: 1:20

3 Living room fireplace plan section
Scale: 1:20

4 Living room fireplace detail
Scale: 1:5

5 Fireplace Cabinet top section
Scale: 1:5

6 Fireplace shelves section
Scale: 1:20

7 Fireplace shelf detail A
Scale: 1:5

8 Fireplace shelf cabinet detail B
Scale: 1:5

9 Fireplace shelf cabinet detail C
Scale: 1:5

10 Fireplace section
Scale: 1:20

11 Fireplace mantle detail
Scale: 1:5

12 Exploded Isometric

13 Fireplace details perspectives

14 Fireplace perspective

NOTE: We will need to fit a small TV. Possible dimension adjustment. Side TBC.

NOTE: Fire space may need to be adjusted to fit a gas heater, as scripted.

REL 03 09 2018

PROJECT NAME		STEVEN JONES-EVANS	
PROJECT NUMBER		CC06	
LIVING ROOM FIREPLACE			
PLANS, ELEVATIONS, PERSPECTIVES			
DATE	SCALE	DATE	SCALE
CARLO CRESCINI	30 AUG 2018	1:20	1:2
CONSTRUCTION	DIRECTOR	PRODUCTION	
SCENE	BOP	LOCATIONS	
SET DEC.	SCRIPT	PROP.	
PROPS	GAFFER	STANDBY	

**CHADSTONE
TAILOR MADE STORE**
(Activation)

Designer Gus Smith
Producer Alex Kember

SHOP VARIATIONS
Renders

Customised store configuration 'example A'

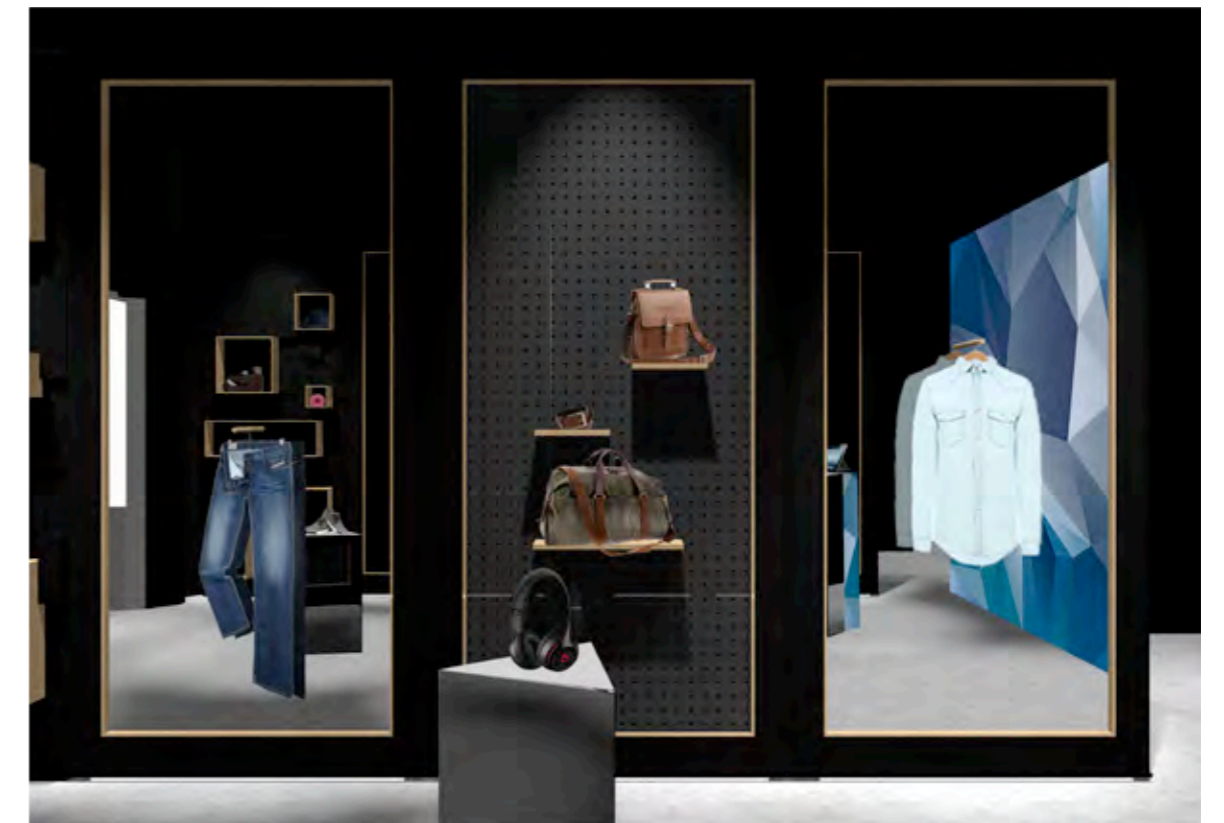

CHADSTONE TAILOR MADE STORE (Activation)

Designer Gus Smith
Producer Alex Kember

SHOP VARIATIONS Renders

Customised 'example B'

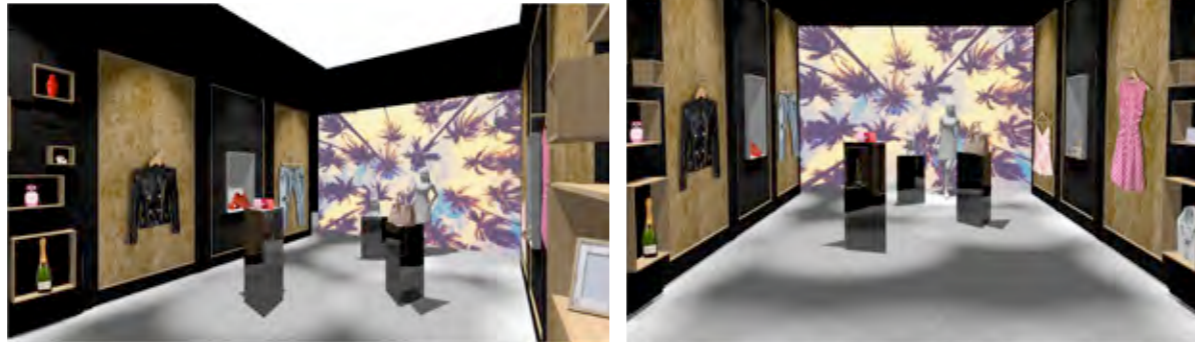

Customised 'example C'

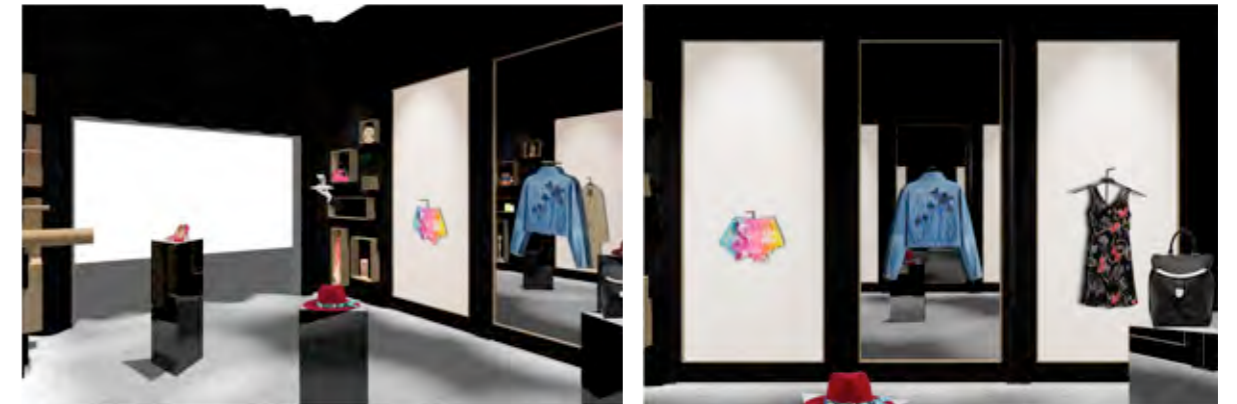

Plans

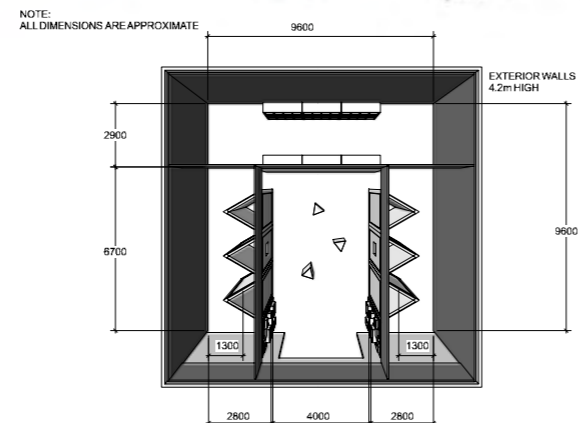

Realised Store

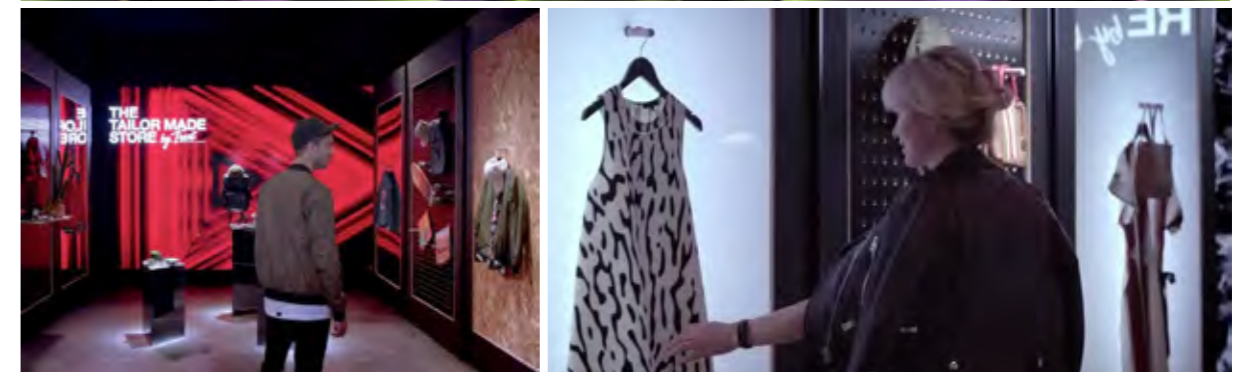

NINE NEWS (Studio Set)

Designer Mark Dyson

SET RE-DESIGN
Renders



READY FOR THIS (Television Drama)

Designer Felicity Abbott

ATTIC SET (Built on location, inside a room) Plans, previsuals & finished set

PLANS

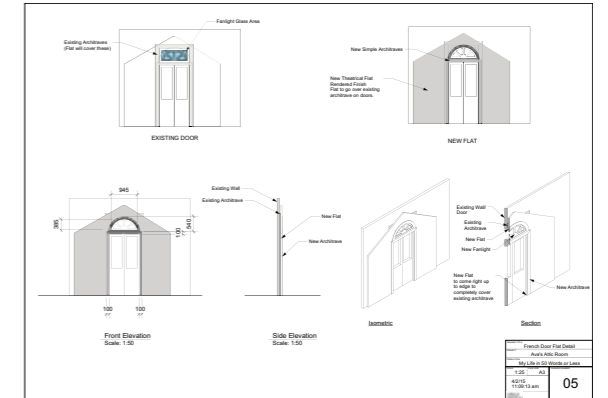
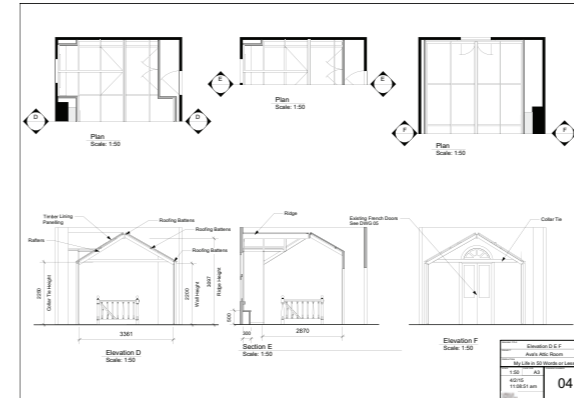
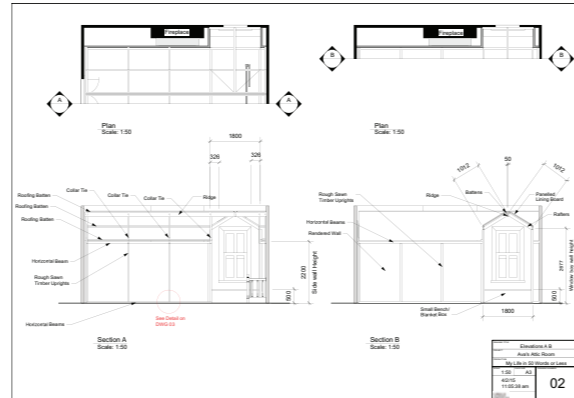
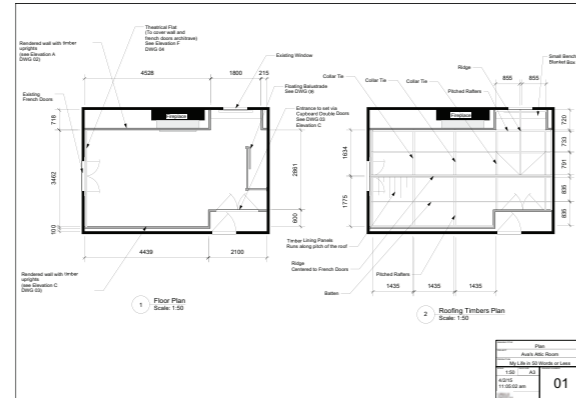

PREVISUALS

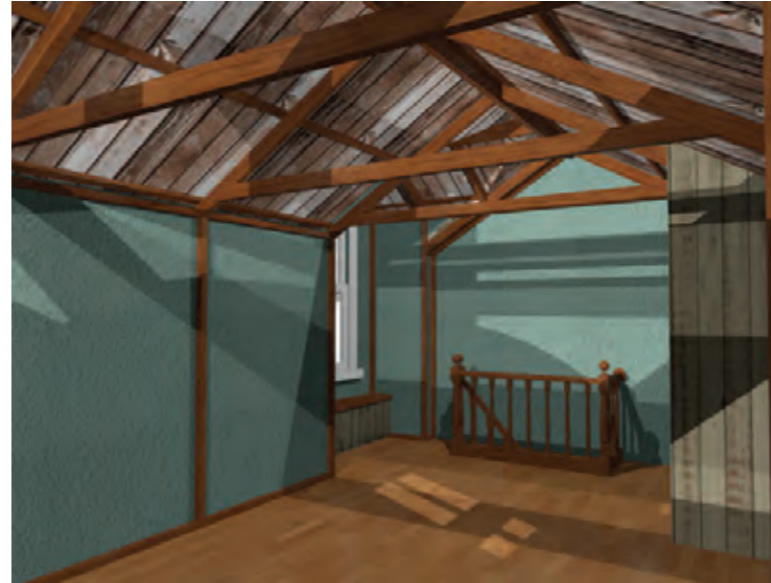
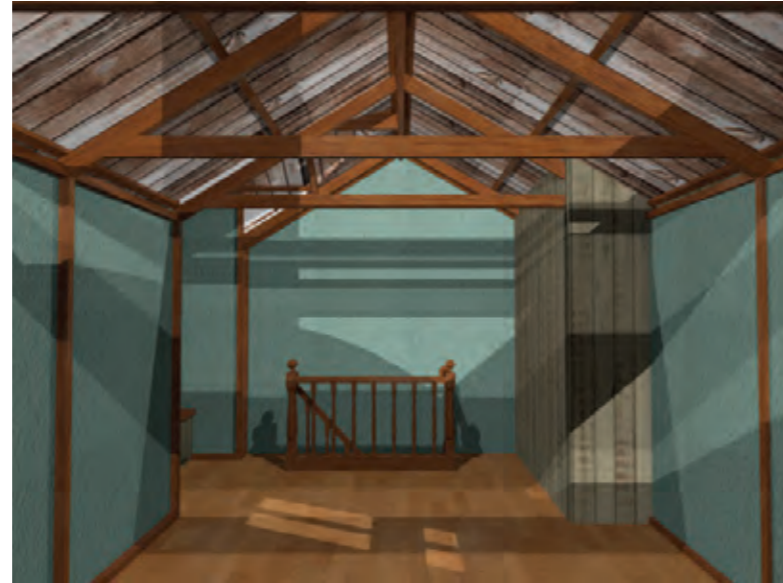

FINISHED SET



READY FOR THIS
(Television Drama)

Designer Felicity Abbott

STAIRWELL
Construction drawings

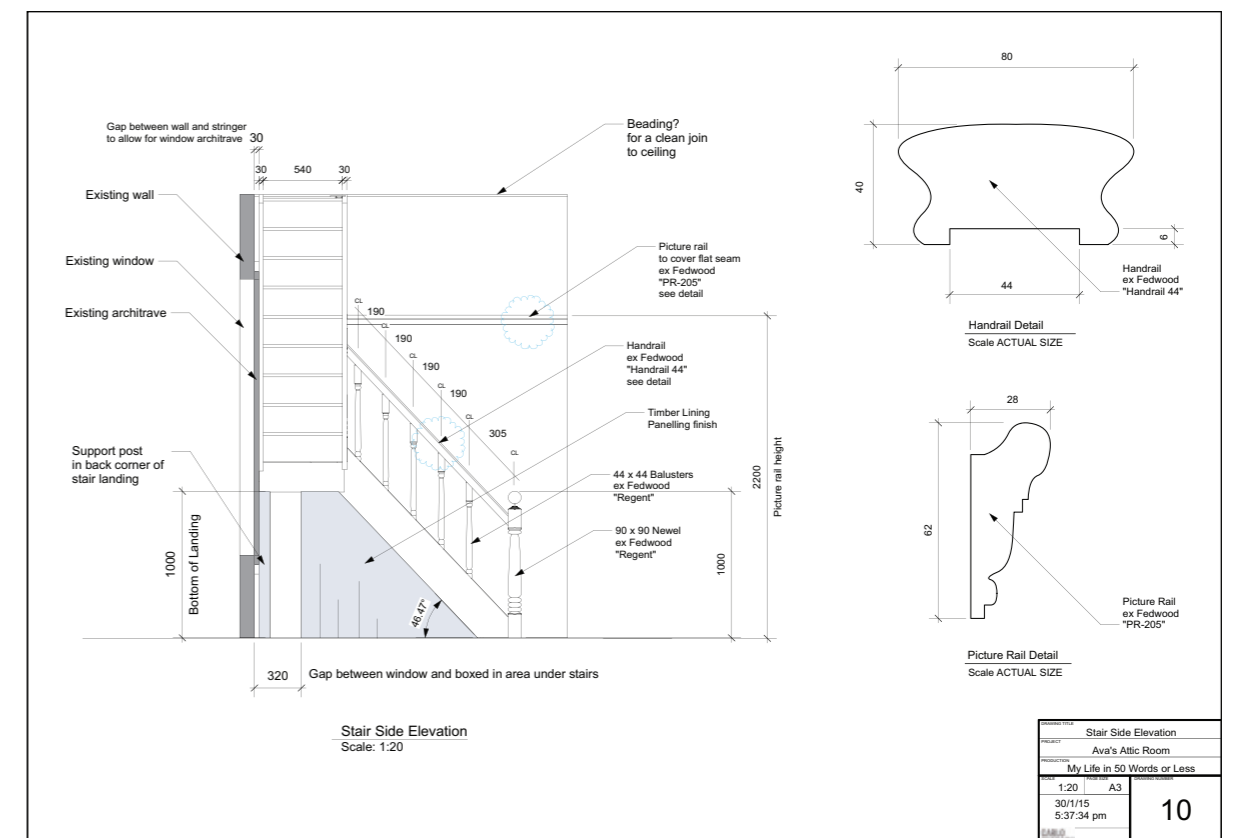
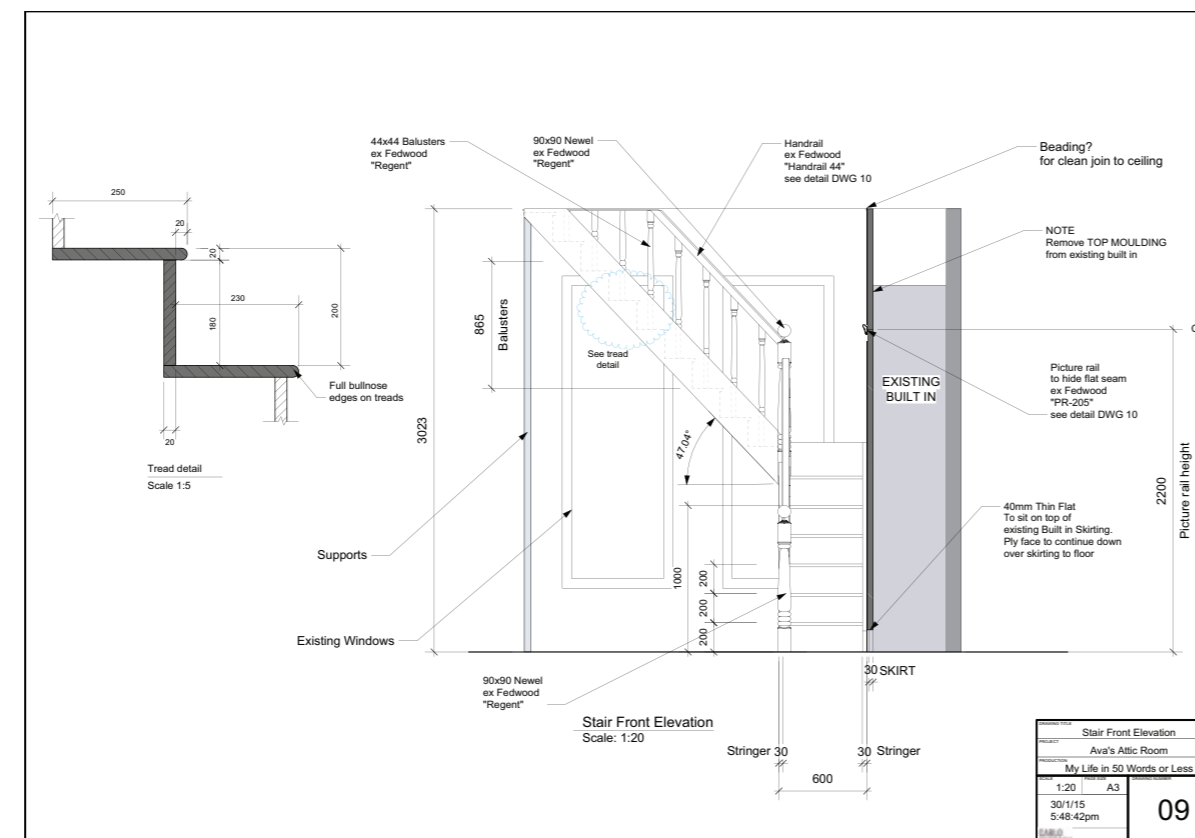
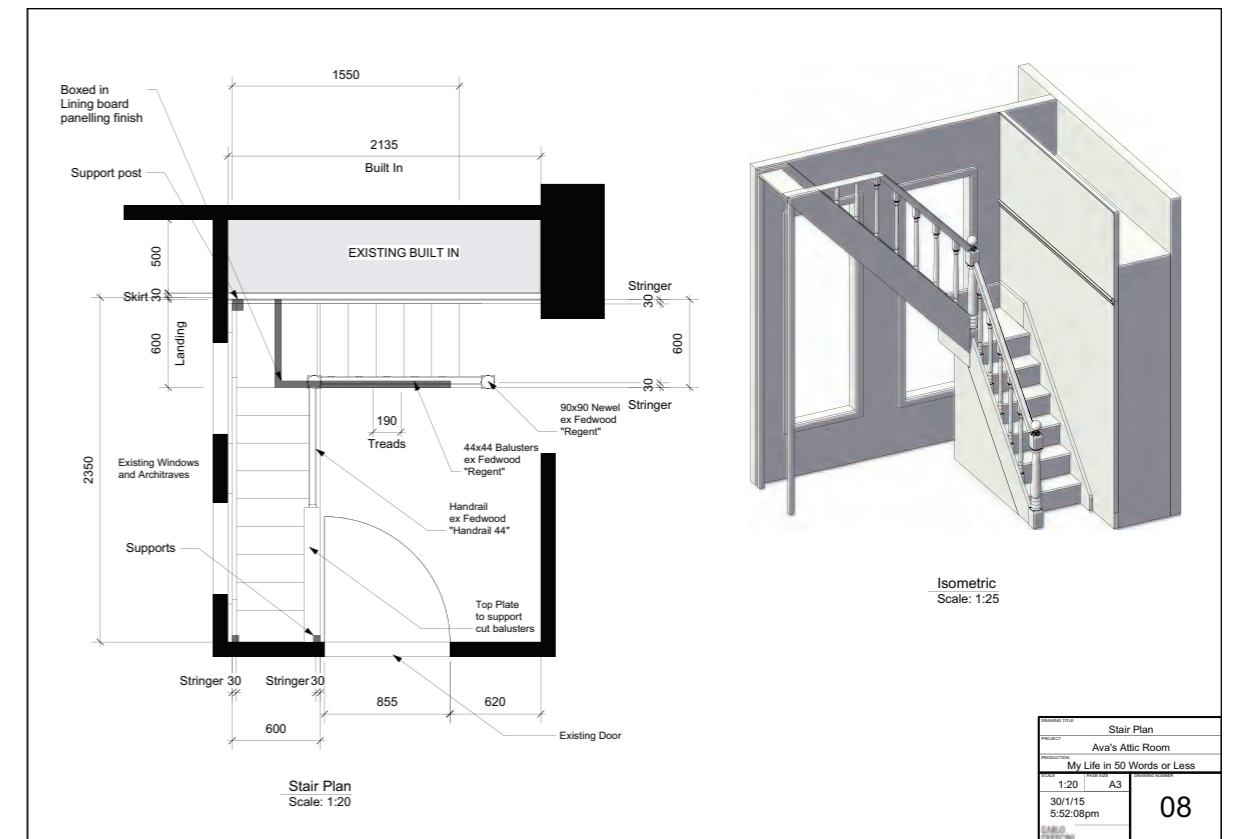
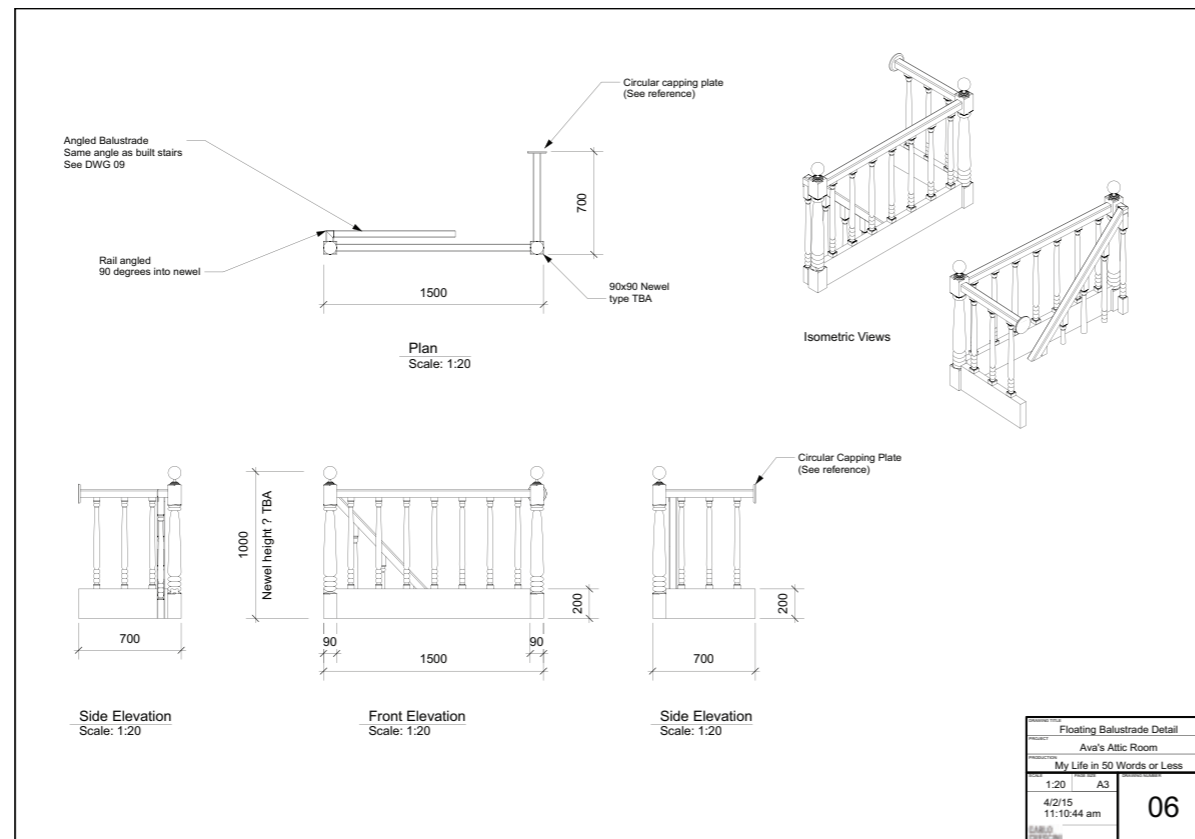

HOME AND AWAY (Television Drama)

Designer Amanda Sallybanks

NEW APARTMENT Studio set drawings

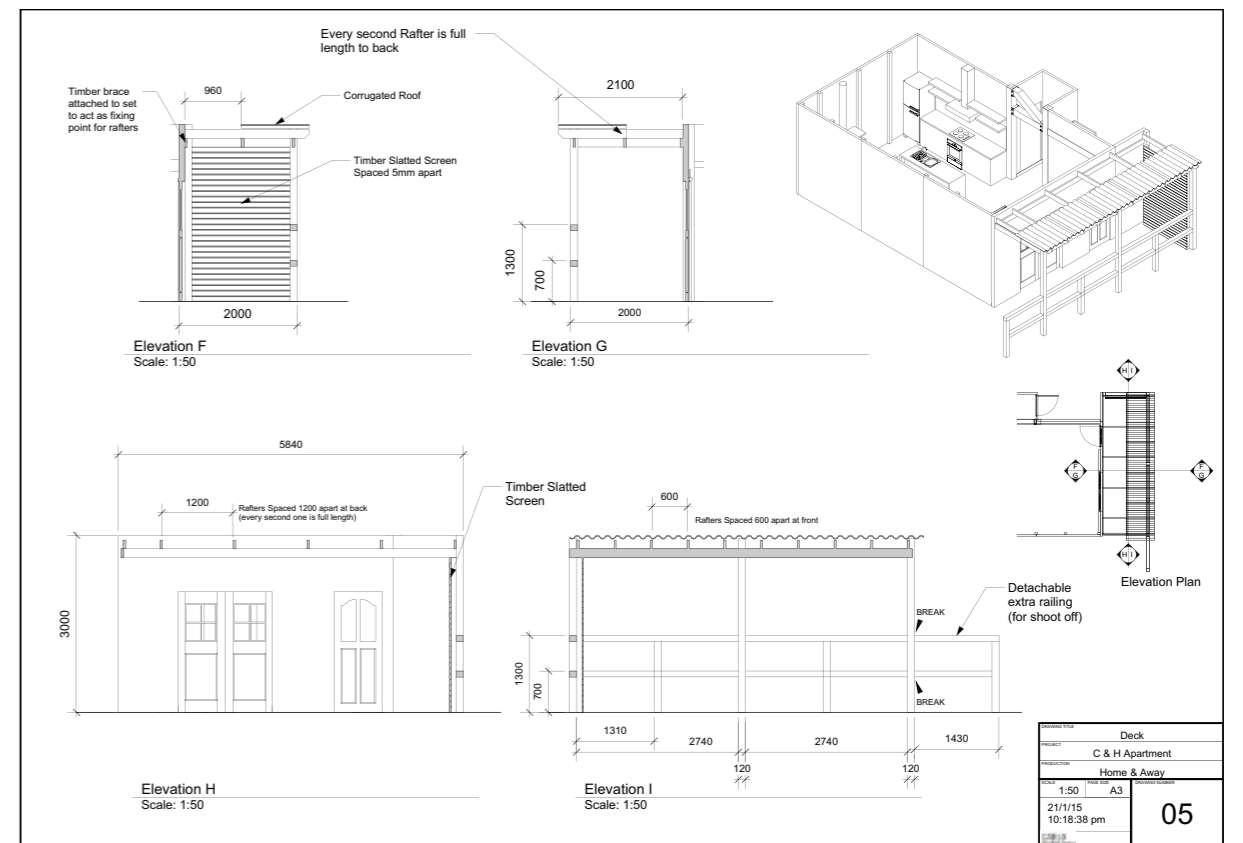
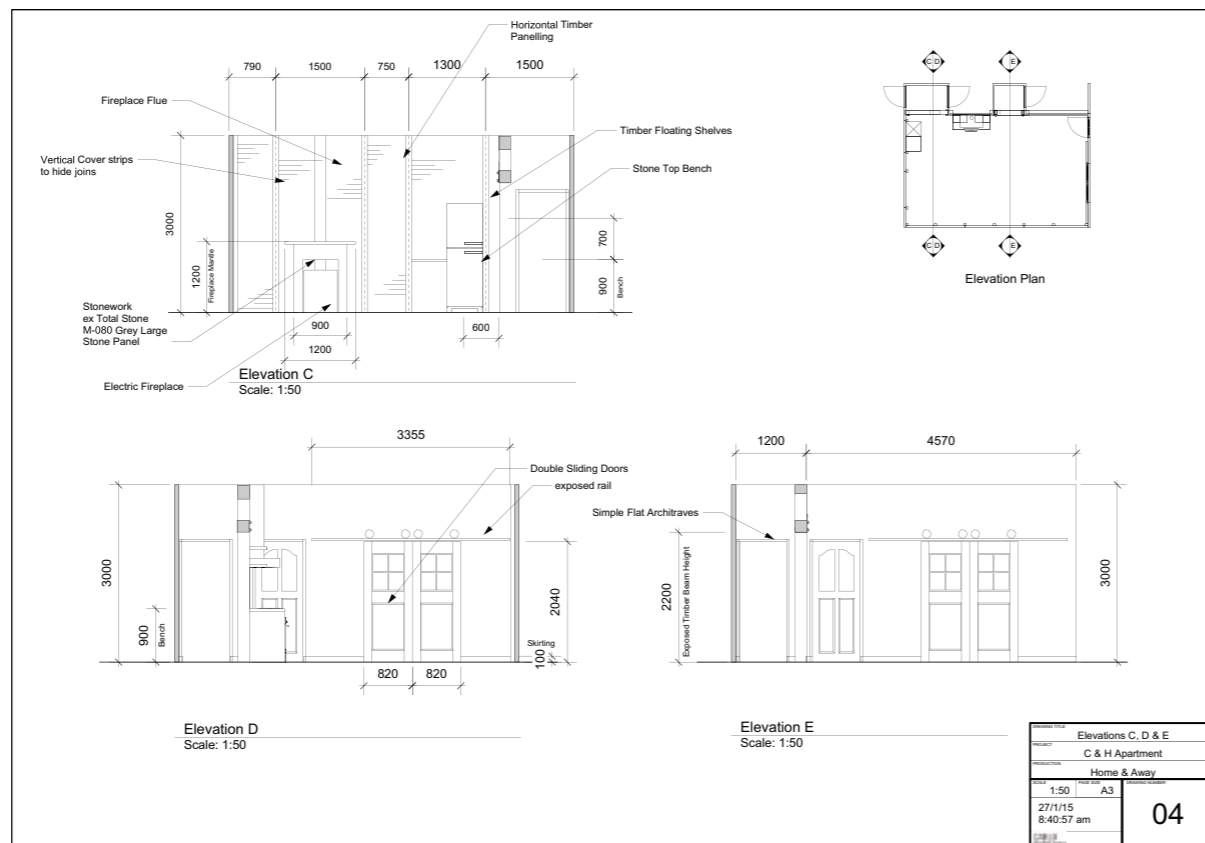
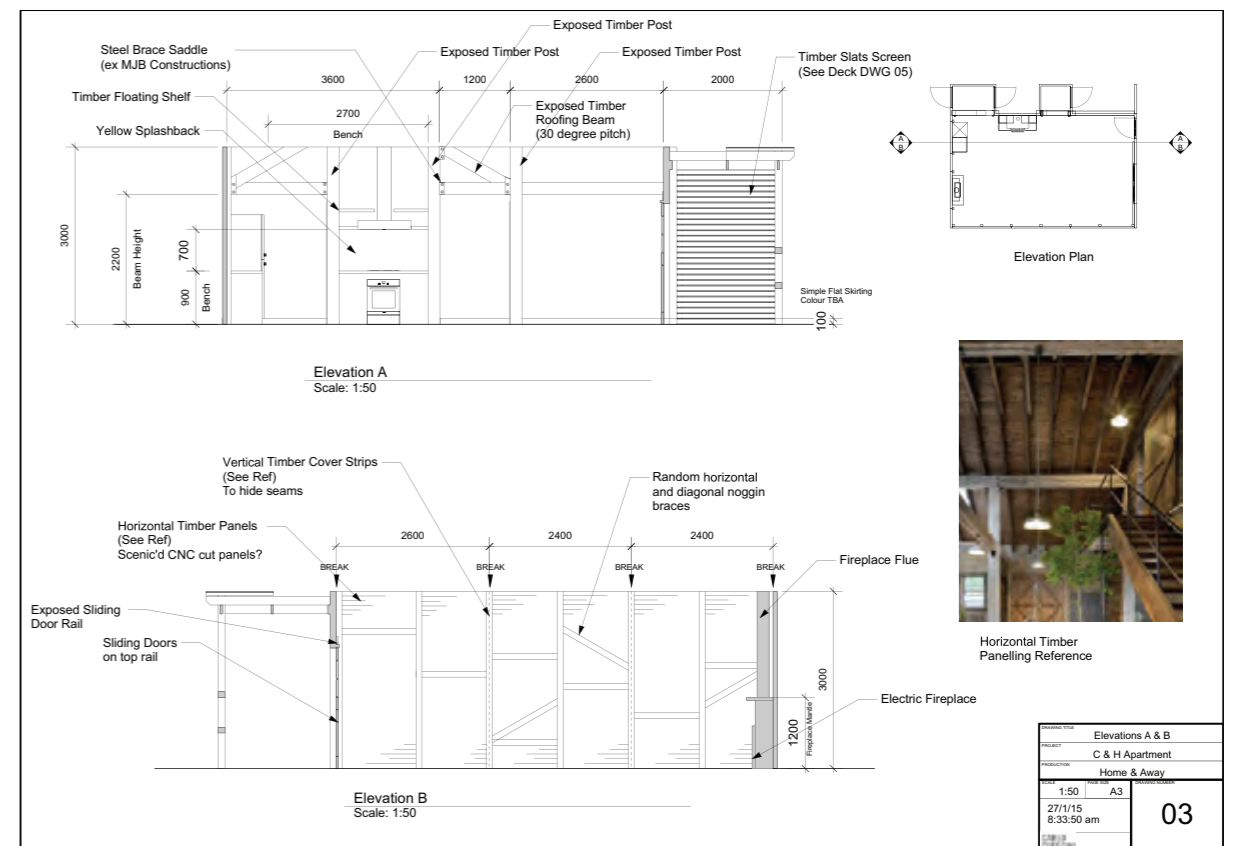
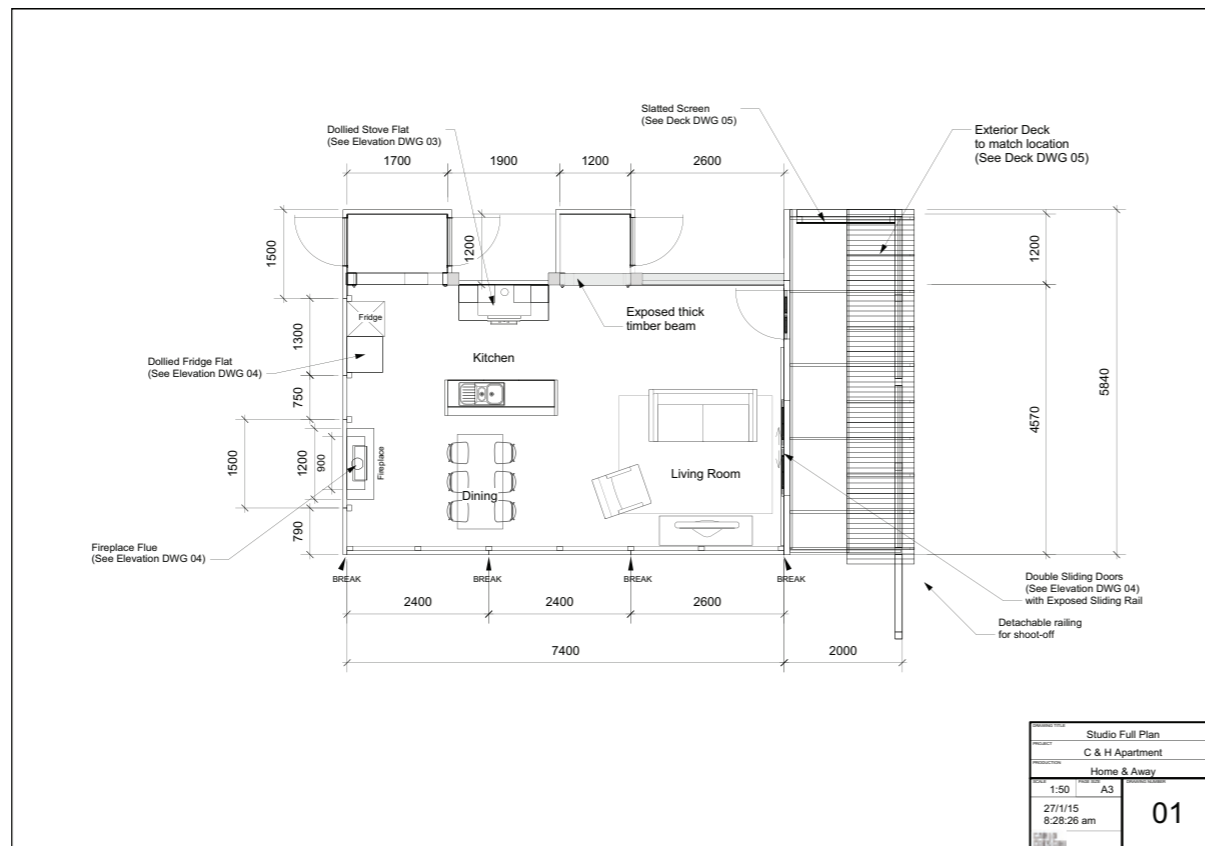

HOME AND AWAY
(Television Drama)

Designer Amanda Sallybanks

APARTMENT DOOR
Construction drawing detail

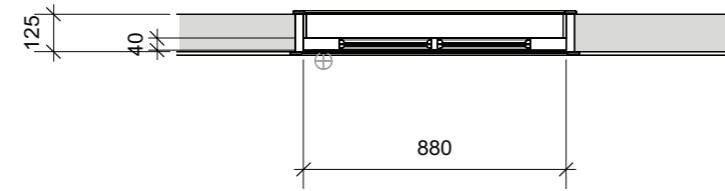

1 Plan
Scale: 1:20

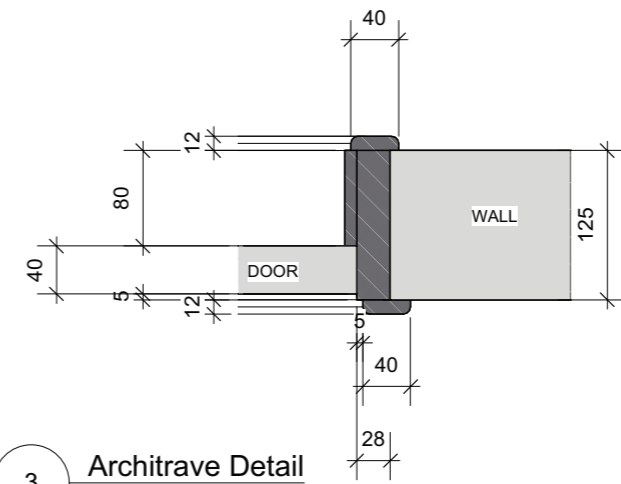

3 Architrave Detail
Scale: 1:5

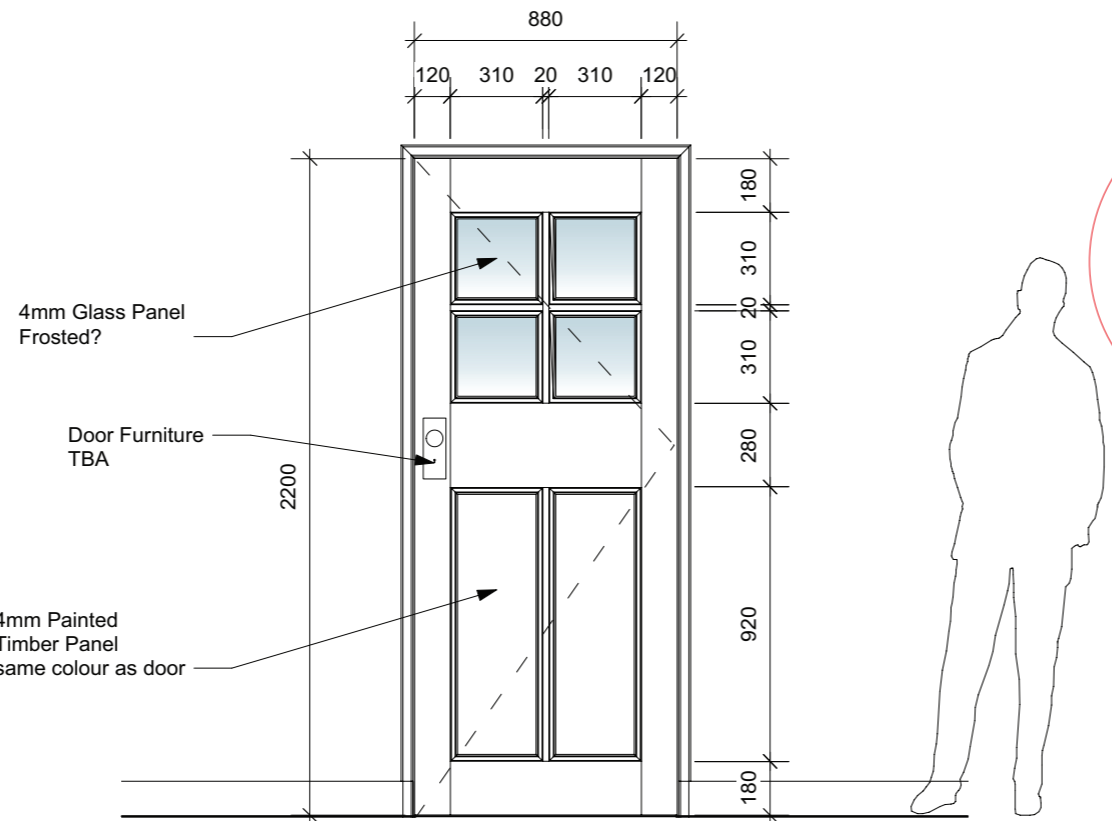

2 Front Elevation
Scale: 1:20

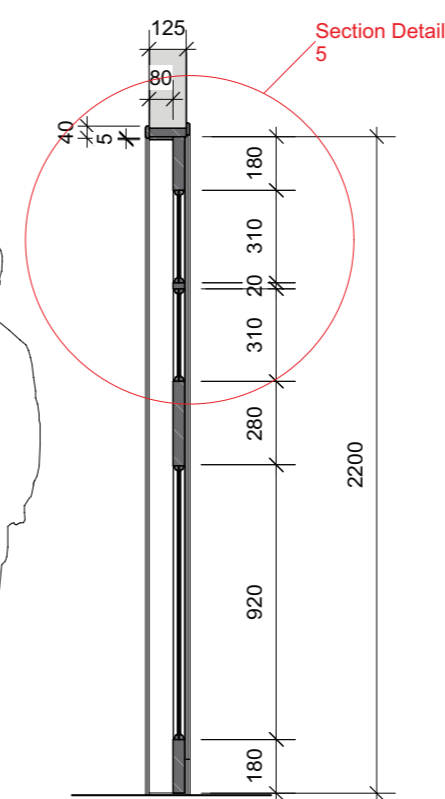

4 Section
Scale: 1:20

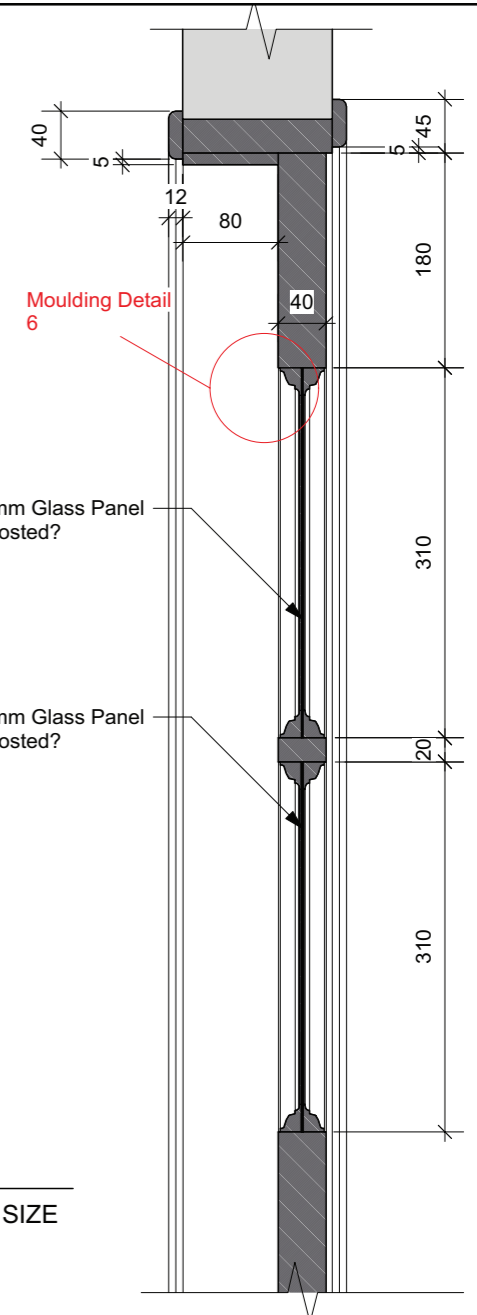

5 Section Detail
Scale: 1:5

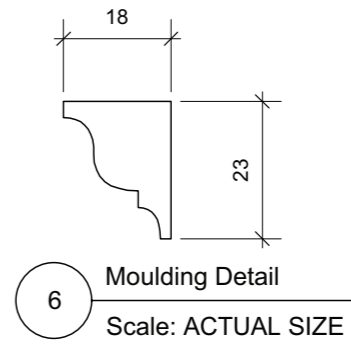

6 Moulding Detail
Scale: ACTUAL SIZE

DRAWING TITLE			
C & H Apartment door			
PROJECT			
C & H Apartment			
PRODUCTION			
Home & Away			
SCALE	PAGE SIZE	DRAWING NUMBER	
1:20	A3	04a	
2/2/15 10:24:07 am			
CARLO CRESCINI			

THE GUNN HOUSE (Interior Design Project)

Interior Designer Sam Rickard

INTERIOR VISUALISATION
Previsuals & realised house

PREVISUALS



REALISED HOUSE



THE GUNN HOUSE (Interior Design Project)

Interior Designer Sam Rickard

INTERIOR VISUALISATION Previsuals

PREVISUALS



BRAND NEW-U (Feature Film)

Designer Greg Shaw

HERO CHAIR Design drawings

BRAINSTORMING

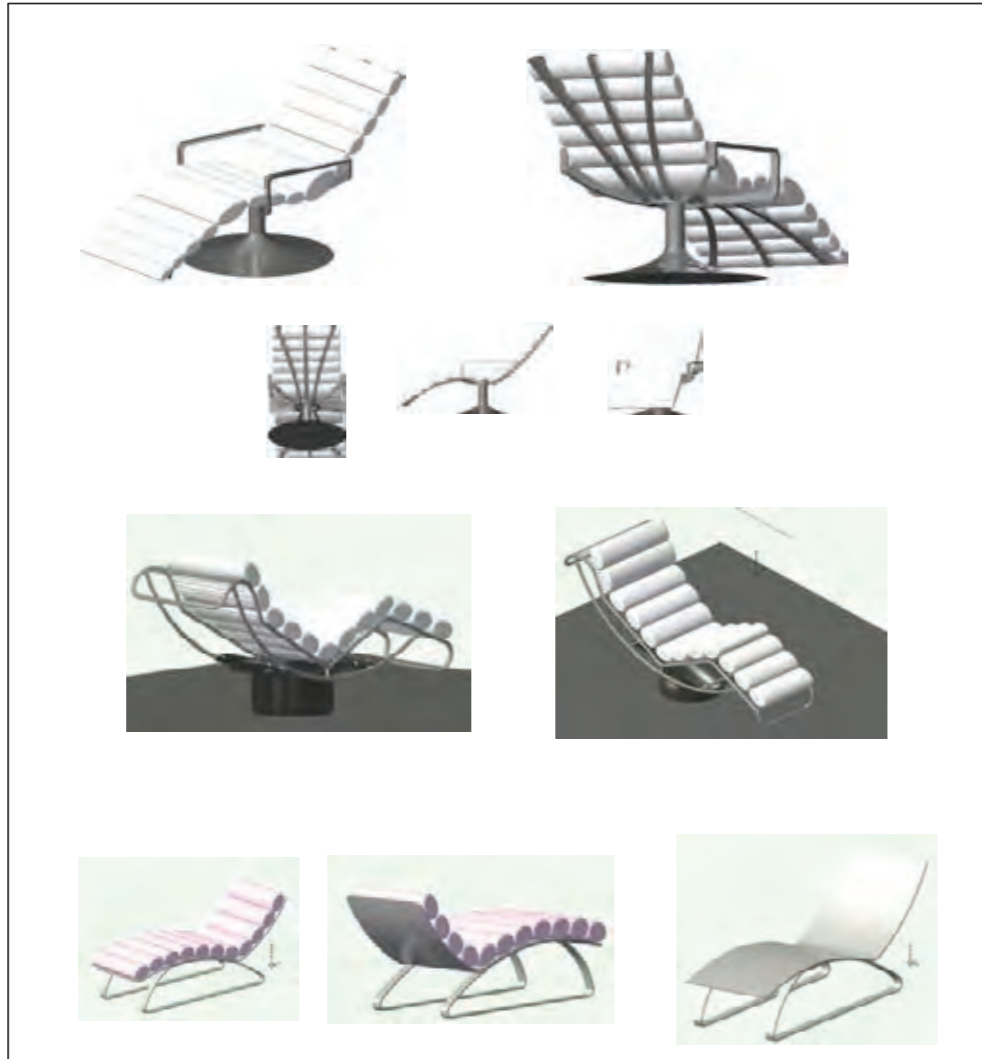

CHOSEN DESIGN

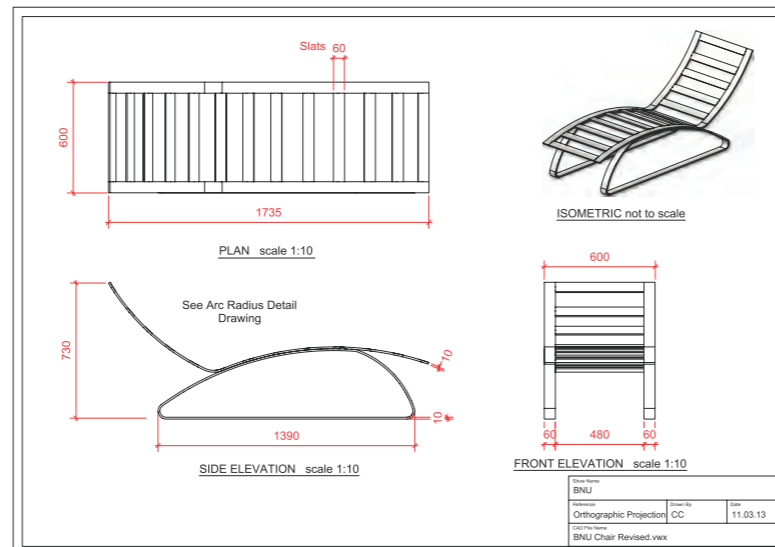
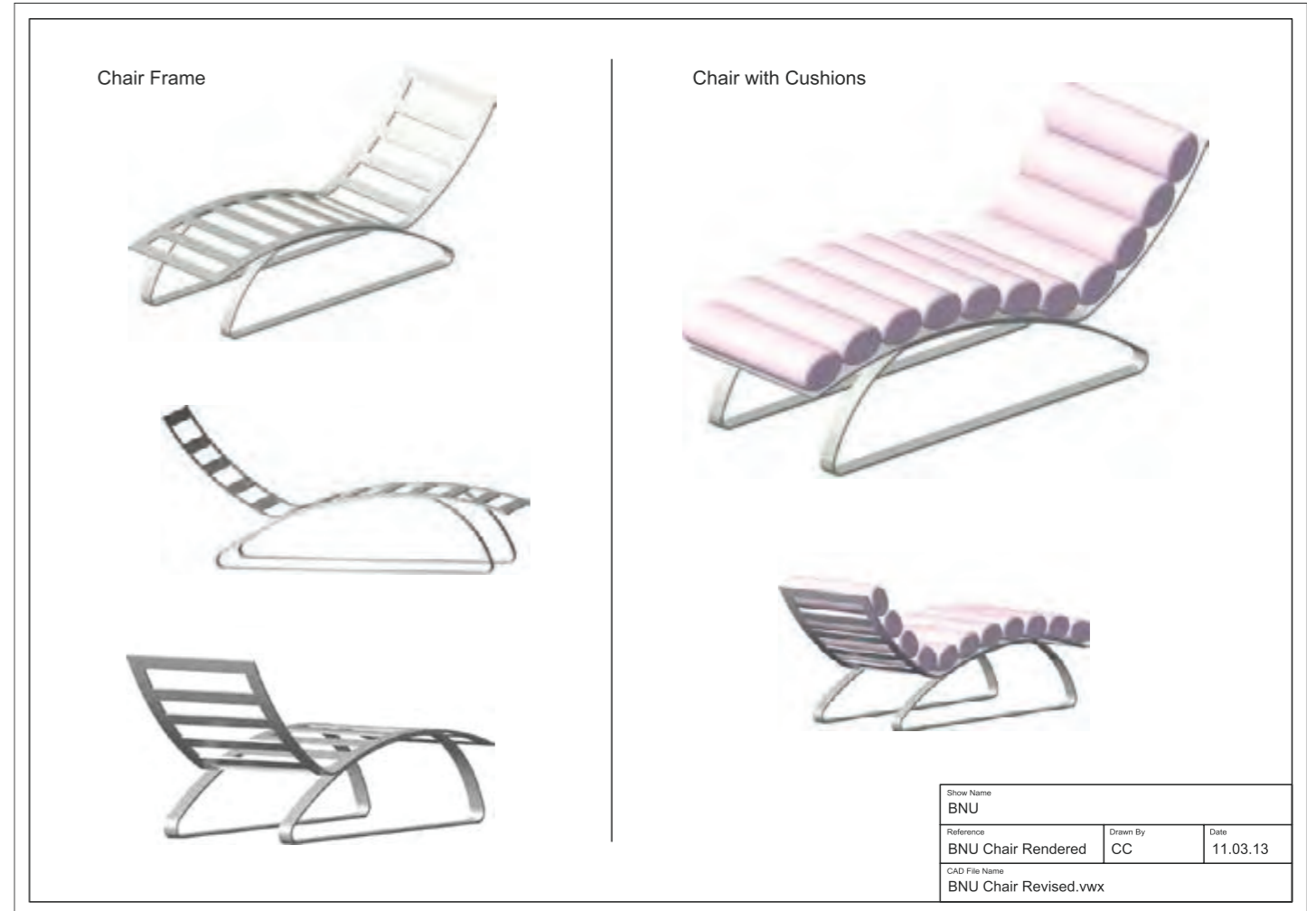

SUPPORTING DRAWINGS OF CHOSEN DESIGN

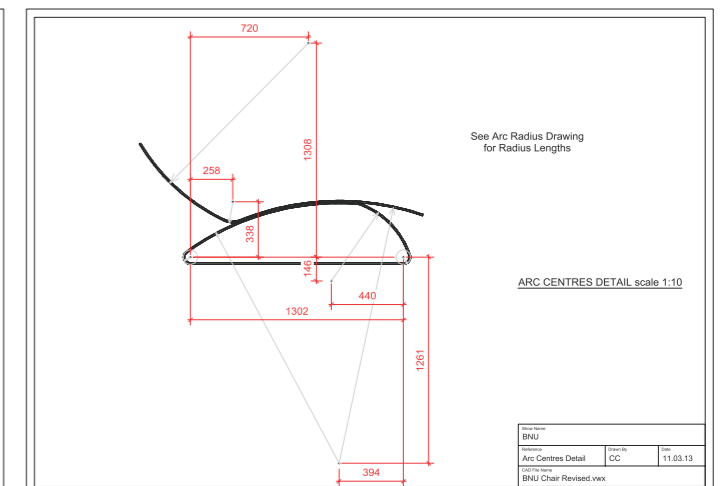
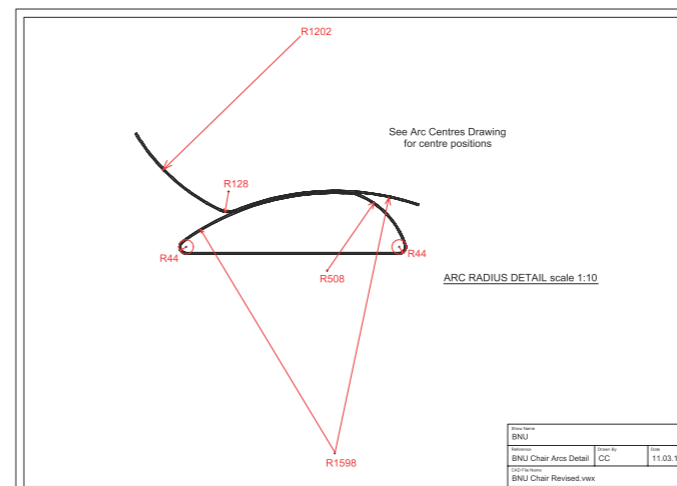

WONDERLAND (Television Drama)

Designer Sam Rickard

POP-UP BAR SET Previsuals & finished set

Previsuals



Finished set



TWO FISTS ONE HEART (Feature Film)

Designer Sam Rickard

KITCHEN SET
Construction drawings



TWO FISTS ONE HEART (Feature Film)

Designer Sam Rickard

BACKYARD BOXING RING Construction drawings

CORNER POST
EYELETS
DRILLED HOLE
ROPE
UNDERLAY
(5000 X 5000)
CANVAS
(5500 X 5500)
RING ROPE
(5000 X 5000)

DETAIL ROPEWORK

DETAIL ROPEWORK

500 250
5000 5500 6000

CANVAS/ROPE REFERENCE

SKIRTING REFERENCE

BRACING AS PER REFERENCE

1500 1390 1040 680

DETAIL FLOORING

CANVAS
RUBBER UNDERLAY
TIMBER DECK
TIMBER DECK

DETAIL FLOORING

DEGREE OF SLOPE TBA
(DRAWING INDICATION ONLY)

CONSTRUCTION OF RING
ALL DONE ONSITE
TO DEAL WITH ANGLE OF LAND

BRACING REFERENCE

1:50	A3	DRAWING NO. 17
ALL MEASUREMENTS ON SITE MUST BE VERIFIED BEFORE COMMENCING CONSTRUCTION		
TITLE TWOFISTSONEHEART		
PRODUCER DAVID ELFICK		
DRAWING BOXING RING		
PRODUCTION DESIGNER SAM RICKARD		
DIRECTOR SHAWN SEET		
DATE 11.10.07	SCALE 1:50	

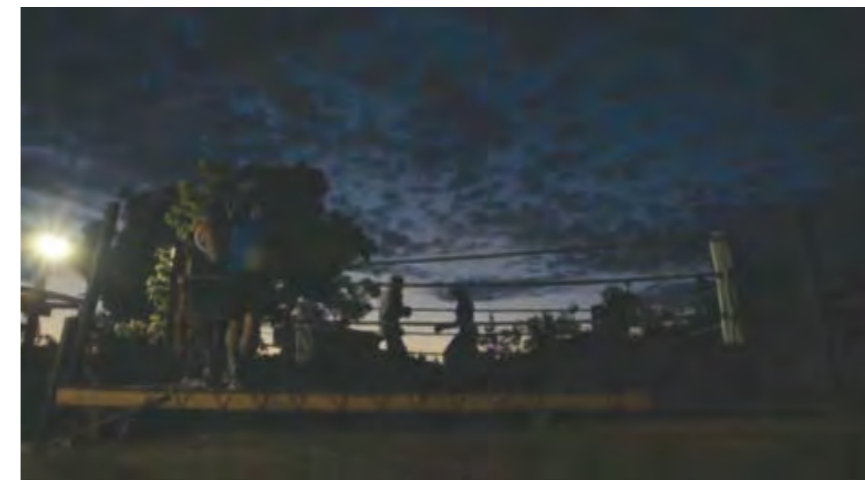

CHAVEZ (Feature Film)

Art Director Byron Broadbent

RECCE LOCATION PLANS

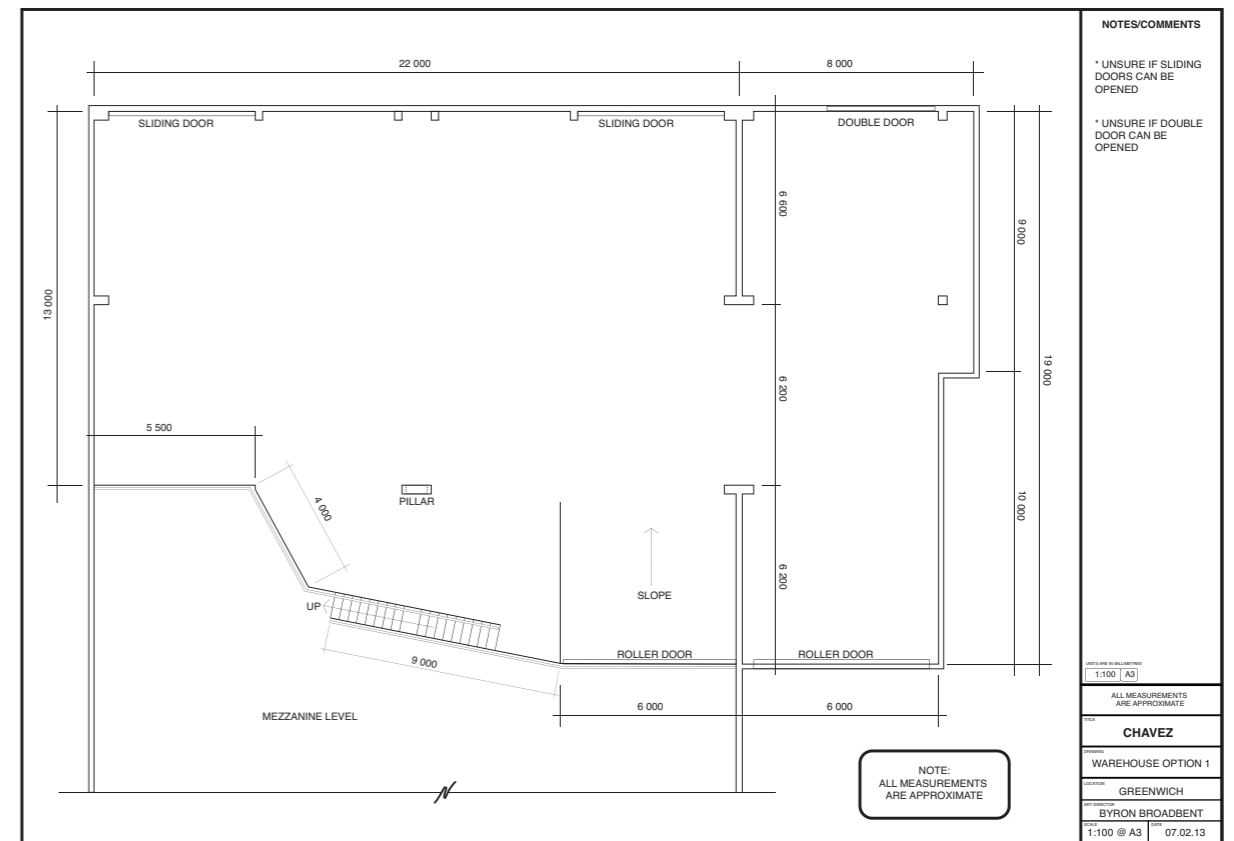
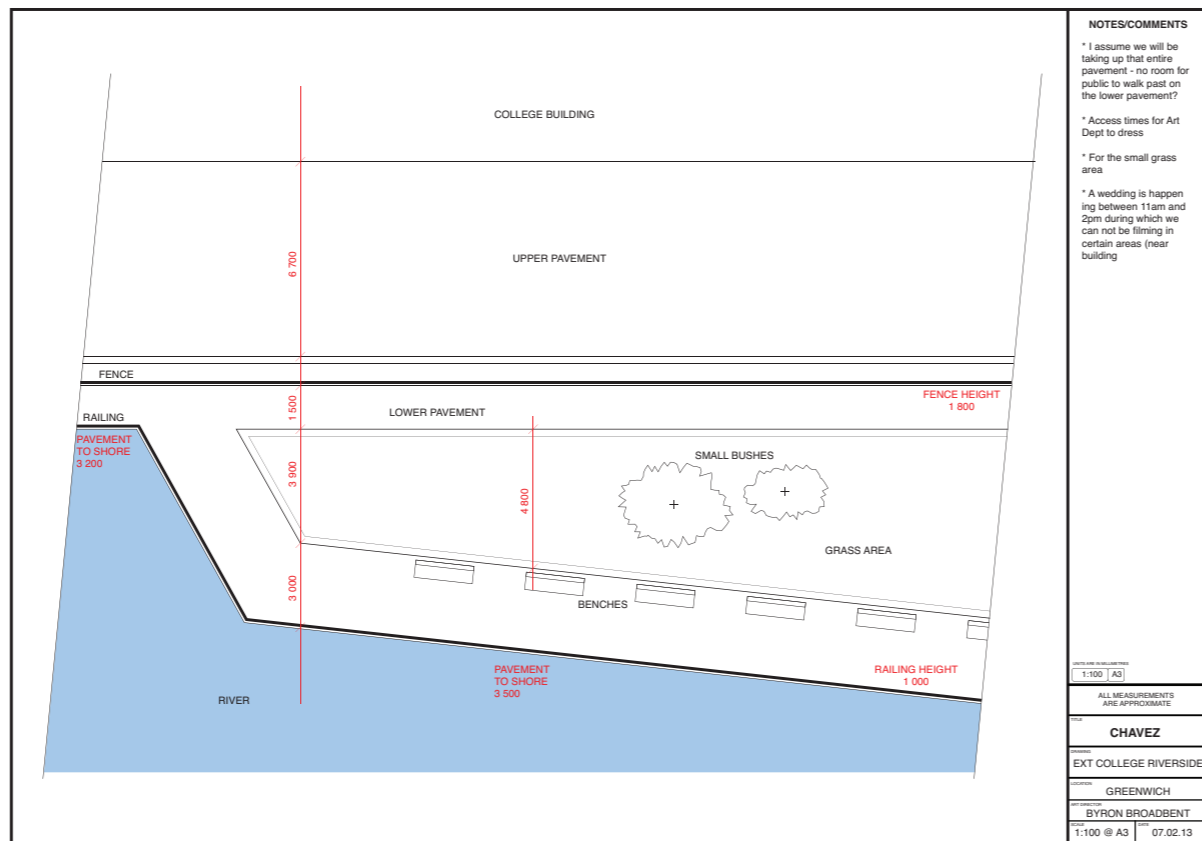
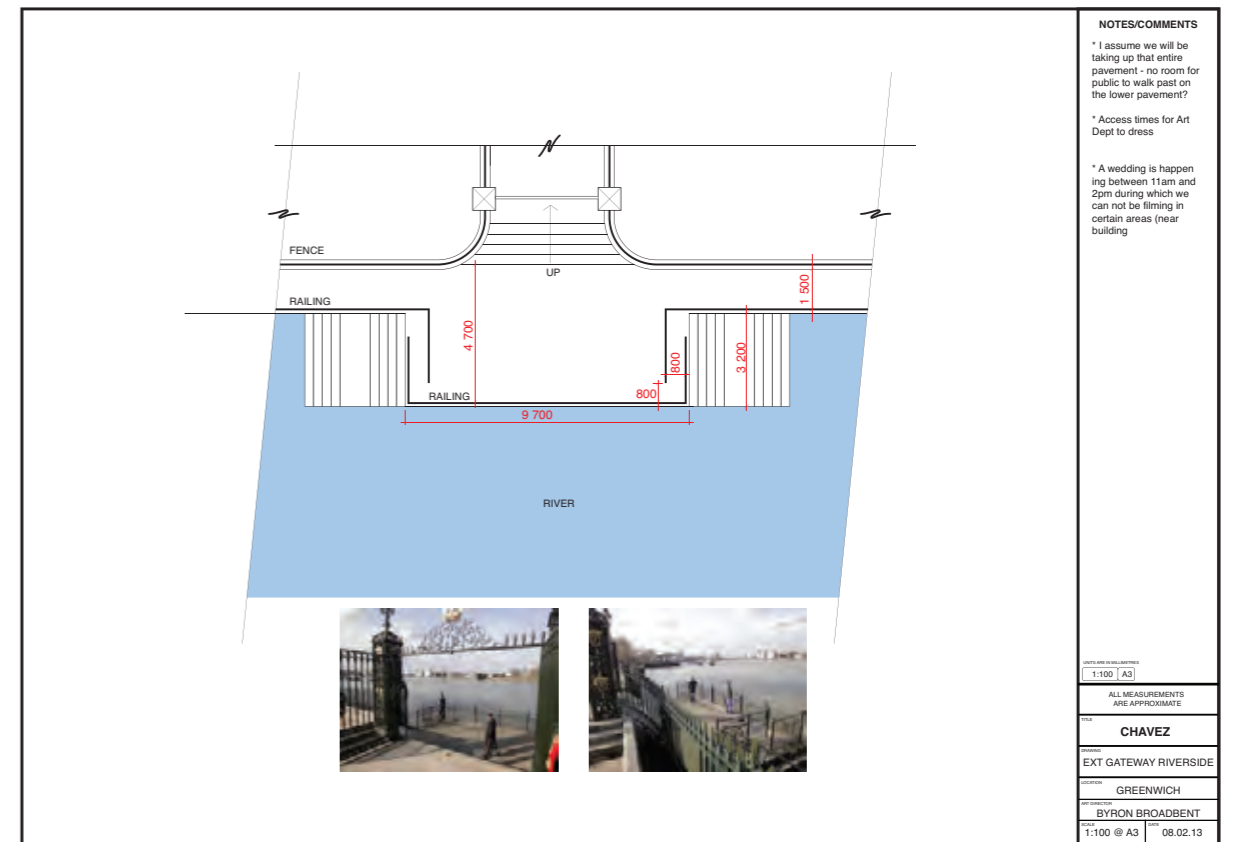
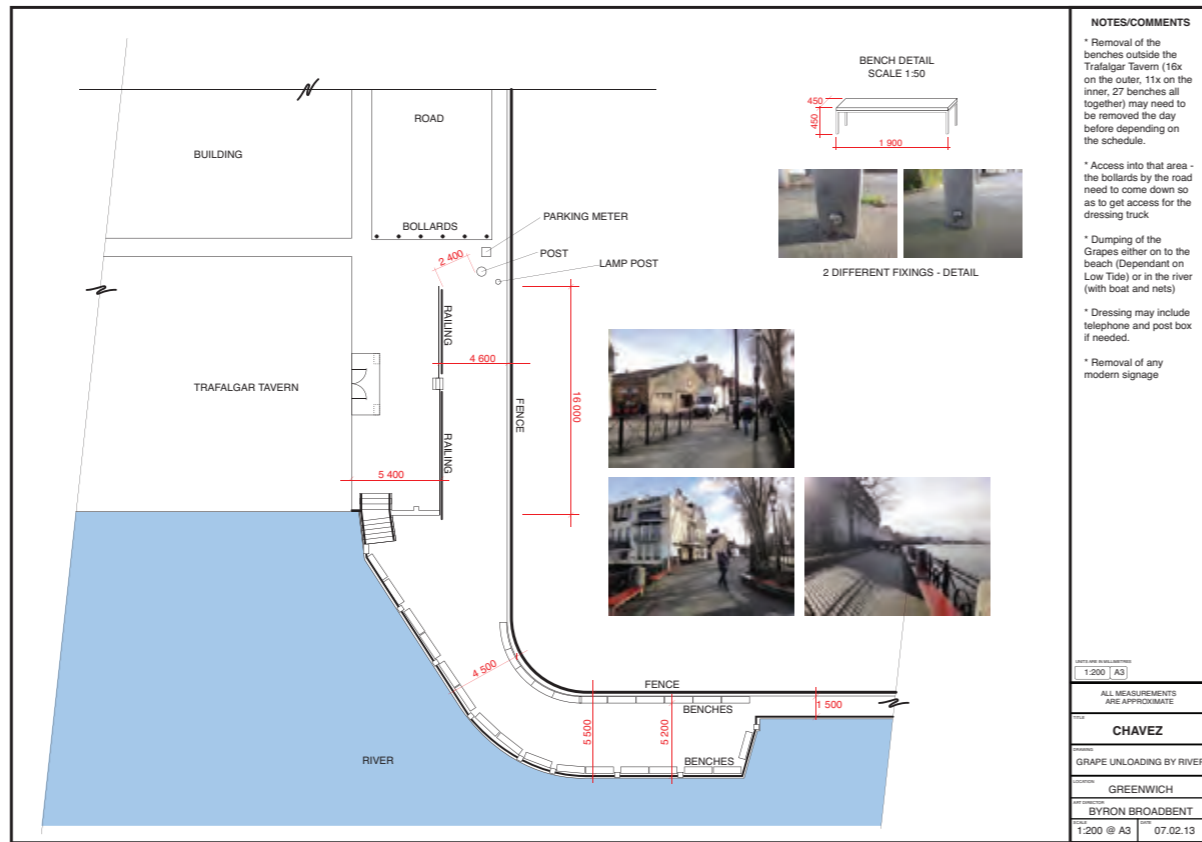

CONTACT INFORMATION

Thanks and look forward to hearing from you

+44 (0)7450 856 503
London / UK

+61 (0)410 511 512
Sydney / AUS

hello@carlocrescini.com
www.carlocrescini.com